

- 1) Kerosene at 20°C flows through the pump. Head losses between 1 and 2 are 8 ft., and the pump delivers 8 hp to the flow at $Q=2.3 \text{ ft}^3/\text{s}$. What should the mercury-manometer reading h ft be?

(20)

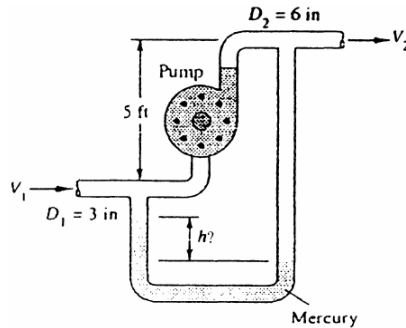

- 2) The horizontal nozzle has $D_1=12 \text{ in}$, $D_2=6 \text{ in}$, with $V_2=56 \text{ ft/s}$. For water at 20°C, a) find V_1 b) estimate P_1 by neglecting head losses c) find the force provided by the flange bolts to hold the nozzle fixed d) What is the head loss between 1 and 2 if $P_1=38 \text{ psi}$? (absolute atmosphere pressure is 15 lbf/in^2)

(20)

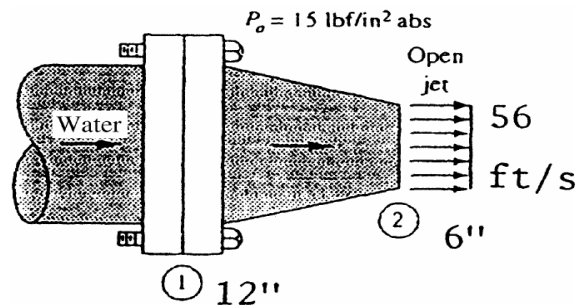

- 3) The pipe bend has $D_1 = 27 \text{ cm}$ and $D_2 = 13 \text{ cm}$. When water at 20°C flows through the pipe at 4000 gal/min, $p_1 = 194 \text{ kPa}$ (gage). Compute the torque required at point B to hold the bend stationary.

(10)

